

# LUZ DE TRABAJO CUADRADO 15W CON 5 LED'S(10-30 V):

- 5 x 3W bombillas de LED
- 10-30 VDC
- Dimensiones 110 x 128 x 41 mm.
- 1150 LM
- Carcasa de aluminio.
- IP68

**Ref. E01LED5**



**manuman**

MANUTENCION Y MANTENIMIENTO INDUSTRIAL, S.L.

Pol. Ind. CONGOST. C/ Can Albareda, 46  
08760 MARTORELL (Barcelona)  
Tel. 937 765 573 - Fax 937 765 701

E-mail: [manuman@manumansl.es](mailto:manuman@manumansl.es)  
[www.manumansl.es](http://www.manumansl.es)

## DIMENSIONES E01LED5:

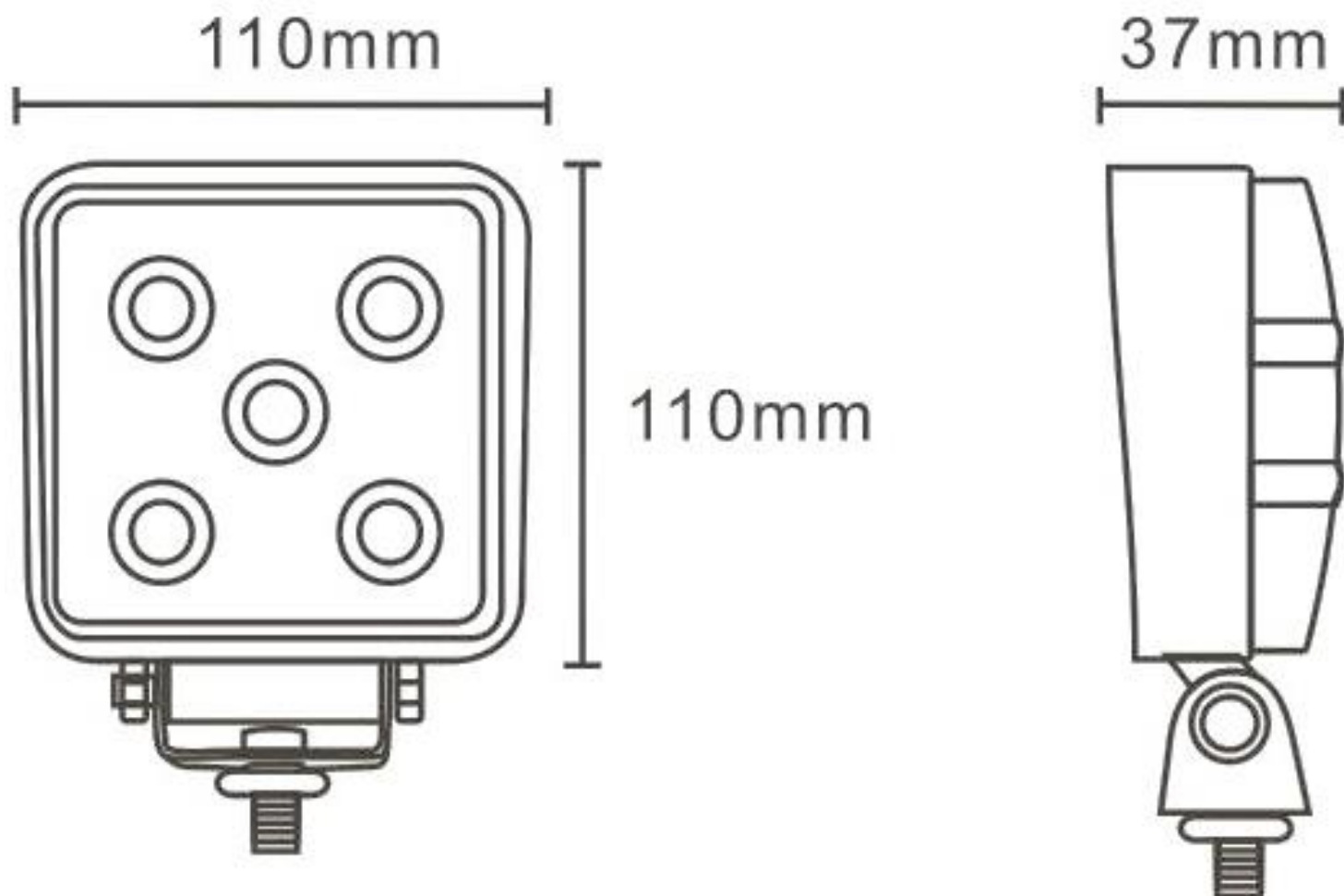

**manuman**

MANUTENCION Y MANTENIMIENTO INDUSTRIAL, S.L.

Po. Ind. CONGOST. C/ Can Albareda, 46  
08760 MARTORELL (Barcelona)  
Tel. 937 765 573 - Fax 937 765 701

E-mail: [manuman@manumansl.es](mailto:manuman@manumansl.es)  
[www.manumansl.es](http://www.manumansl.es)